

4

3

2

1

- 1.0 GENERAL NOTES
 - 1.1 ALL METRIC DIMENSIONS ARE IN BRACKETS [X. X]
 - 1.2 FOR PATENT INFO: <https://www.adwpat.com>

- 2.0 DESIGN NOTES
 - 2.1 FITS MONOPOLES 30"-60" O.D.

- 3.0 MANUFACTURING/SPECIAL REQUIREMENTS
 - 3.1 TIGHTEN ALL BOLTS SECURING FLAT PLATES BY THE TURN-OF-NUT METHOD. TIGHTEN ALL U-BOLTS USING TURN-OF-NUT METHOD WITH ATTENTION TO LEAVE EQUAL DISTANCE AND EQUAL FORCE ON EACH LEG OF THE U-BOLT.

- 4.0 TEST

- 5.0 PACKAGING
 - 5.1 PACKAGING SHALL MEET ANDREW REQUIREMENTS PER DOCUMENT IS-PL-3005
 - 5.2 PRINTED DOCUMENT TO BE PLACED INSIDE POLYBAG AND THEN IN SHIPPING CONTAINER
 - 5.3 EXTRA HARDWARE MAY BE SUPPLIED, BAGGED AND SHIPPED

REVISIONS			
REV.	DESCRIPTION	DATE	APPROVED
F	REDESIGN	AW 10NOV04	TP
G	REDESIGN WELDMENT	MSM 16NOV11	TP
H	NEW DESIGN WELDMENT	MSM 18FEB11	8000015106
J	UPDATED DRAWING FORMAT; ADDED PACKAGING VIEW	YC1059 16OCT25	BA1025 50105402AMO

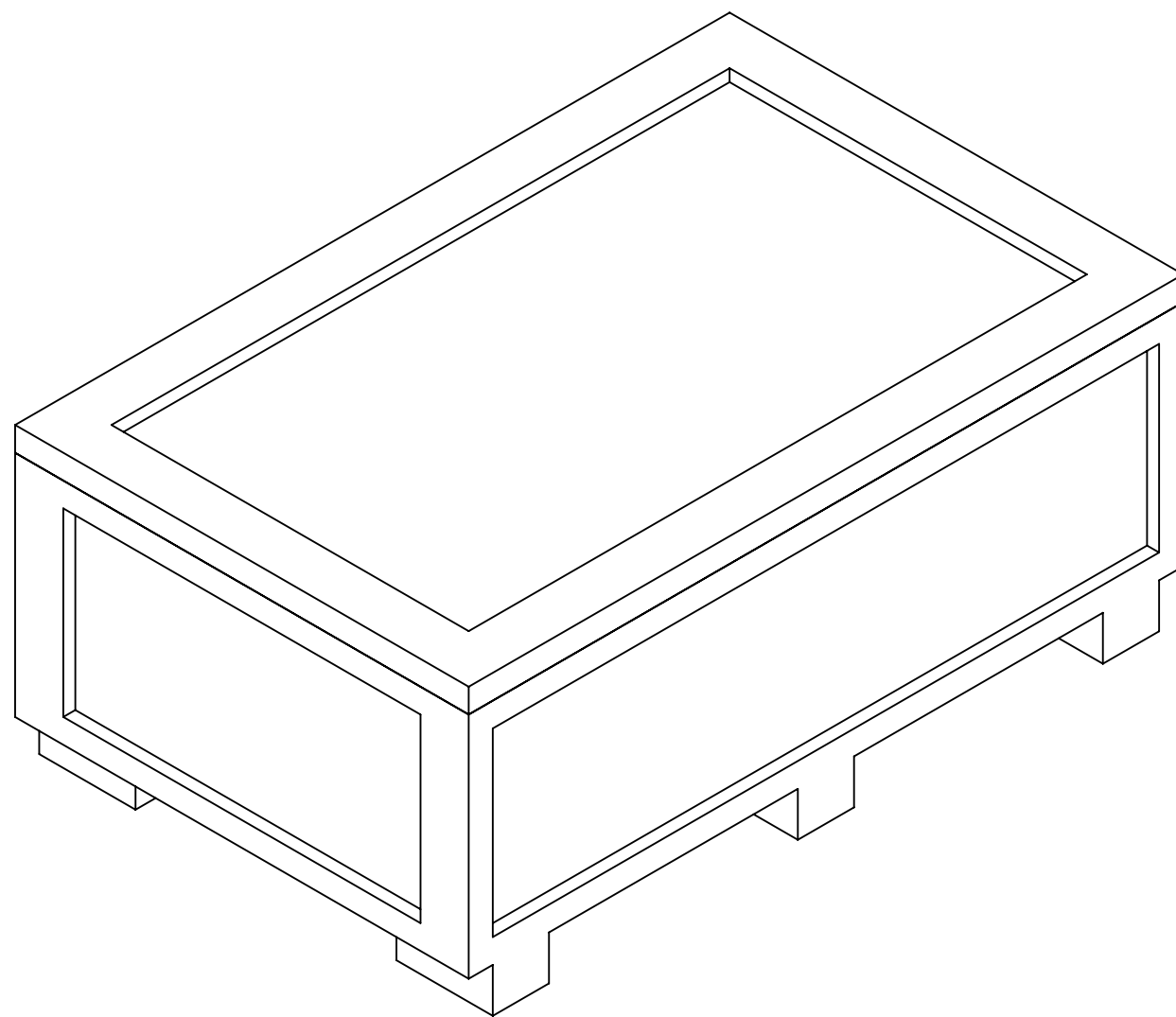

PACKAGING VIEW

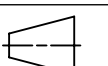

ANDREW® an Amphenol company

TOLERANCES		SAP MATERIAL MASTER						
1 PLACE .X[X] ± 0.12[3.0]	3 PLACE .XXX[X] ± 0.030[0.8]	MC-RM3060-4						
2 PLACE .XX[X] ± 0.06[1.5]	ANGLES ± 2°							
FINISH		MATERIAL						
UNLESS OTHERWISE SPECIFIED DIMENSIONS ARE IN INCHES INTERPRET PER ANSI Y 14.5M-1994	NAME	DATE	FOUR SECTOR UNIV RING MOUNT 30"- 60"					
	CE MSM	06JUL11						
	RW YC1059	10/21/2025						
	AD YMENG	10/21/2025						
	RE YMENG	10/21/2025						
ECN 50105402AMO		SCALE 1:8	DOCUMENT NO. MC-RM3060-4					
SIZE	Auth Group INSL	MODEL						
C	 	VERSION	STATUS	REVISION	VERSION	STATUS	REVISION	SHEET 1 OF 2
		00	RE	A	01	RE	J	
		DRAWING						

DENSITY		lbs/in³
MASS	251.94	lbs
VOLUME	1940.61	in³
SURFACE AREA	9576.62	in²
HEIGHT	11.5	
LENGTH	64.3"	
WIDTH	64.3"	

Confidential

4

3

2

1

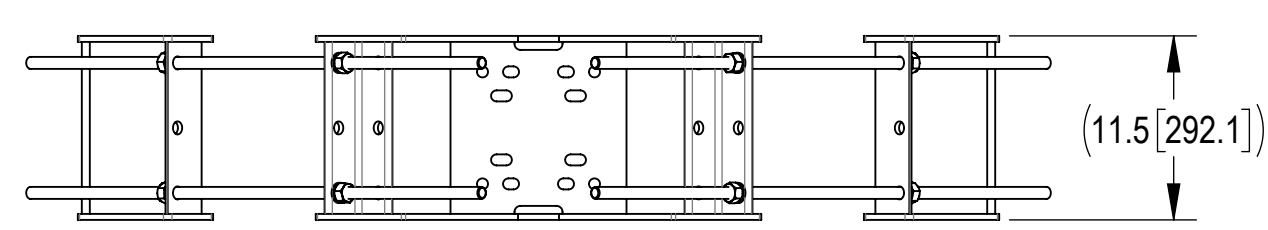
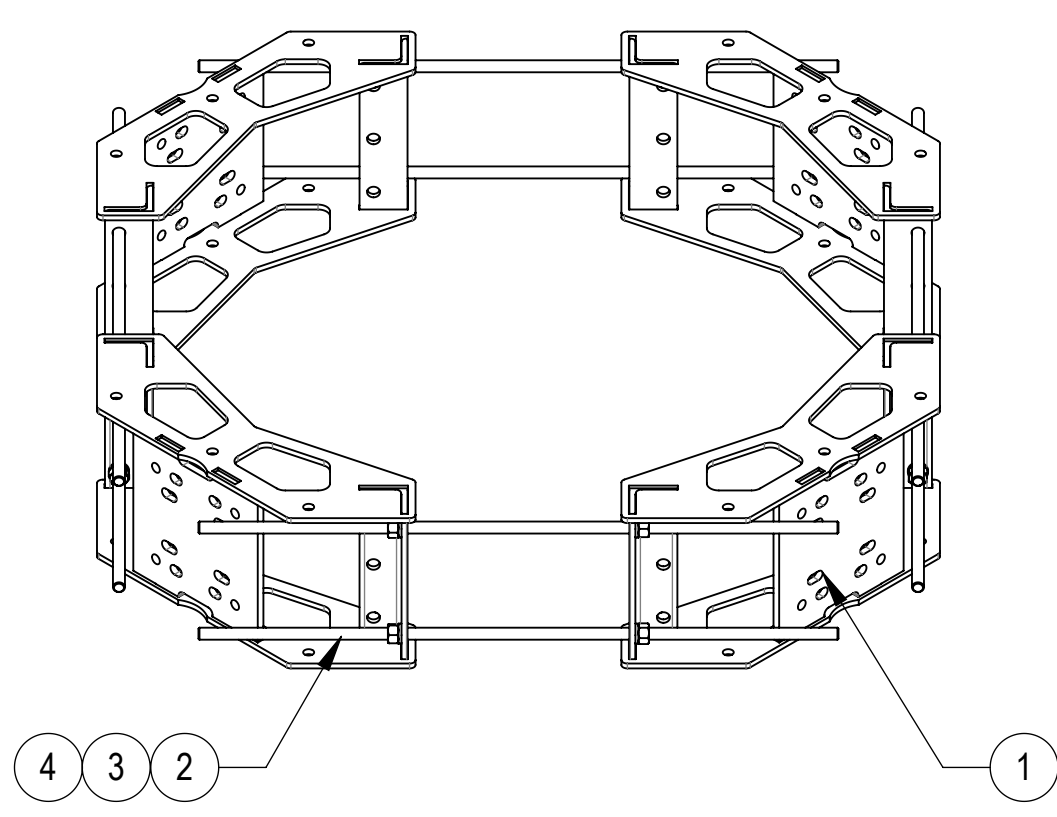
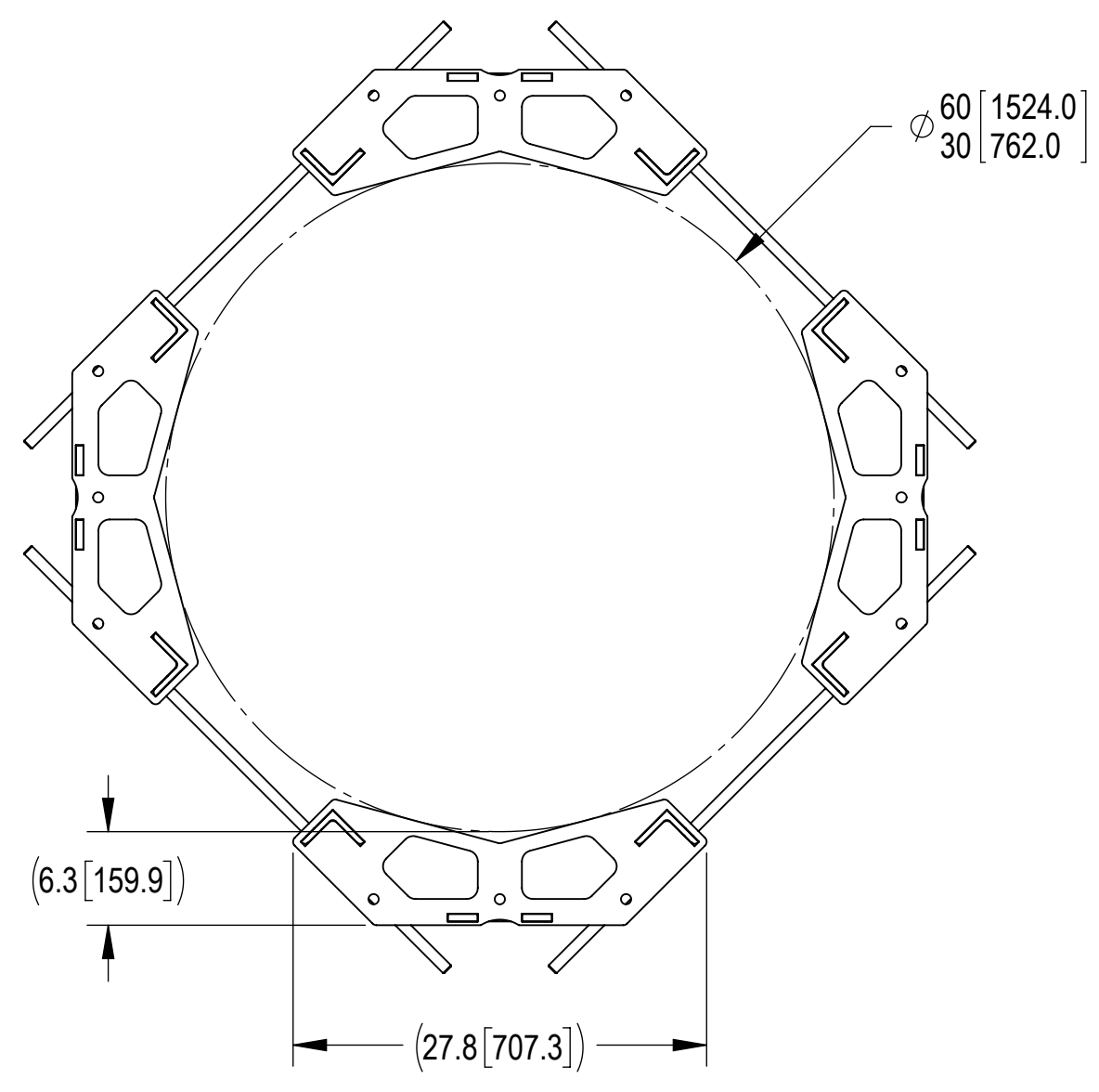

COMPONENT PART NUMBERS PROVIDED FOR ASSEMBLY PURPOSES;
INDIVIDUAL COMPONENTS MAY BE SHIPPED AS PARTS WITHIN AN INCLUDED KIT.

ITEM	PART NO.	DESCRIPTION	QTY.	WEIGHT	NOTE NO.
1	RM3060404	30-60 4 SECTOR RM WLDMNT	4	52.28 LBS	
2	MT38440	3/4" X 40" GALV THREADED ROD GRADE B7	8	4.98 LBS	
3	GWL-06	3/4" GALV LOCK WASHER	16	0.04 LBS	
4	GN-06	3/4" GALV HEX NUT	16	0.15 LBS	

ANDREW an Amphenol company

TITLE
FOUR SECTOR UNIV RING MOUNT 30"- 60"

SIZE **C** SCALE **1:12** DOCUMENT NO. **MC-RM3060-4**

DRAWING			SHEET 2 OF 2
VERSION	STATUS	REVISION	
01	RE	J	

Confidential